

Anzahl:	1 Stk.
Material:	S235/1.4301
Oberfläche:	
Massstab:	1:2.5/1:20/1:10
<small>Diese Zeichnung ist Eigentum der AMBOSS Metallbau AG. Sie darf ohne unsere Einwilligung weder kopiert, weitergeleitet, noch zur Ausführung benutzt werden.</small>	
<b>AMBOSS Metallbau AG</b> Industriestr. 1 6345 Neuheim 041 530 71 30 info@amboss-ag.ch	

<b>geländerXpress.ch</b> Übersicht Staketengeländer Flex	
Detail	
Projekt-Nr.	Zeichnungs-Nr.
	Rev.:
<b>AMBOSS</b> <small>- AMBOSS Metallbau AG -</small>	
geländer  press.ch	
14000 - A01 -	

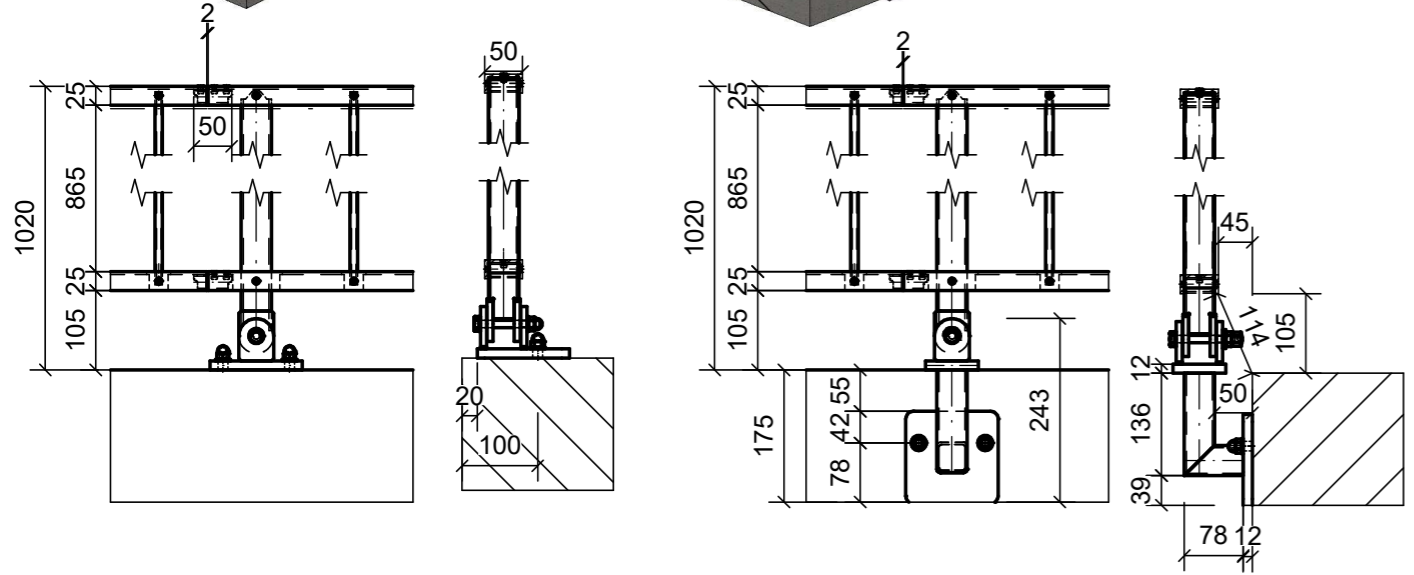

Klemmteil (2 pro Geländer)  
 Blech 12 1.4301

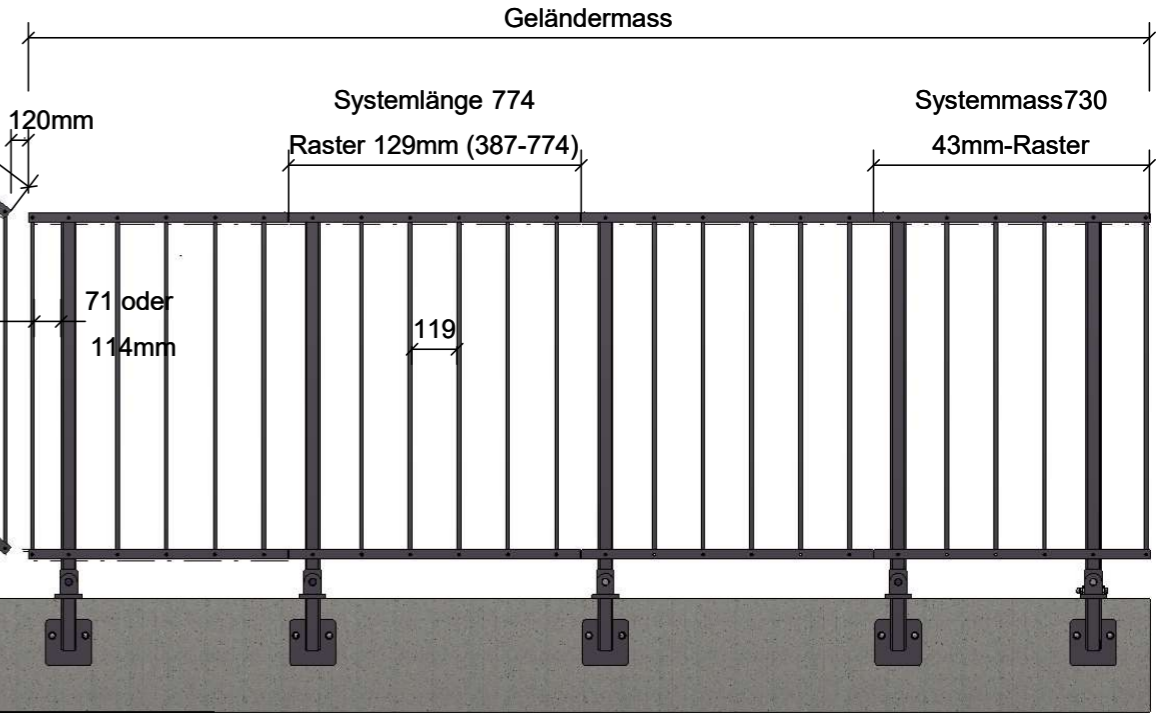
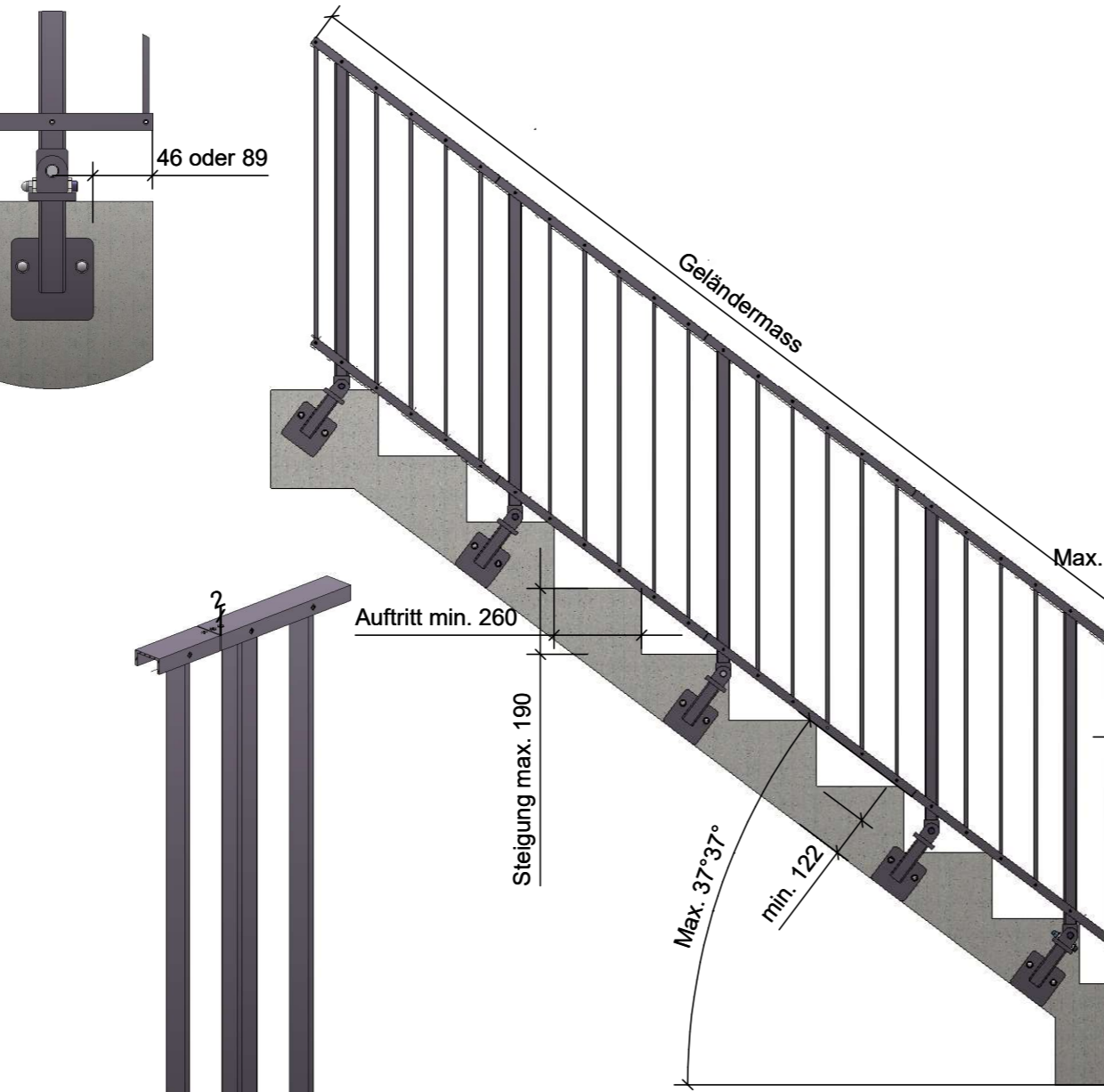
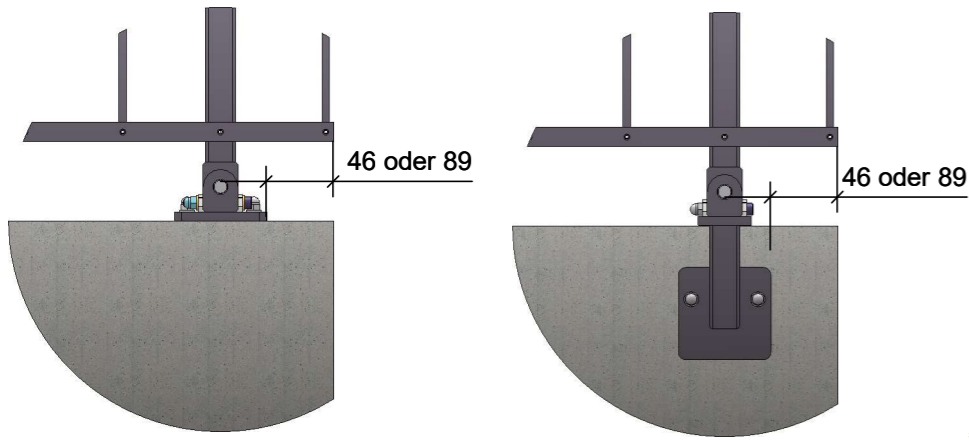