

Anzahl:	1 Stk.	geländerXpress.ch
Material:	S235	Xpress-Glasgeländer
Oberfläche:	-	Musterzeichnung
Masstab:	1:20	Detail
<small>Diese Zeichnung ist Eigentum der AMBOSS Metallbau AG. Sie darf ohne unsere Einwilligung weder kopiert, weitergeleitet, noch zur Ausführung benutzt werden.</small>		AMBOSS Metallbau AG Sihlbruggstr. 3 6345 Neuheim 041 530 71 30 info@amboss-ag.ch
		<b>AMBOSS</b> <small>AMBOSS Metallbau AG</small> geländerXpress.ch
		Projekt-Nr. Zeichnungs-Nr. Rev.: <b>XXX - A02 -</b>

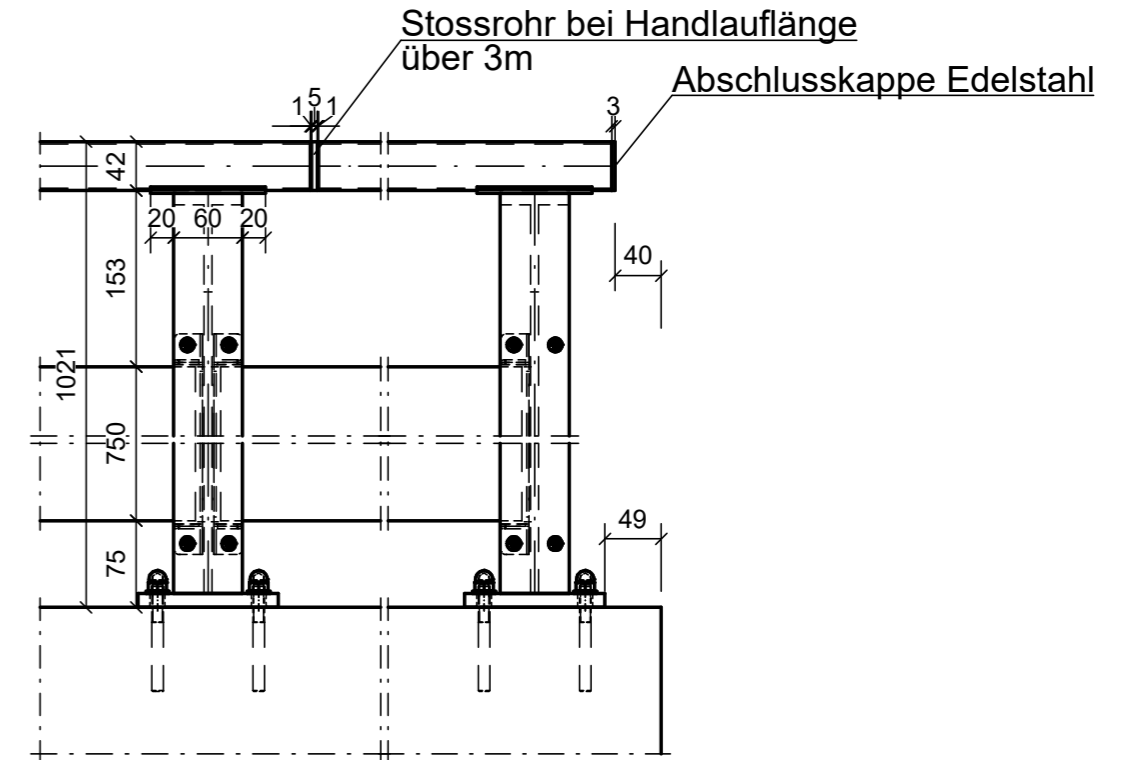

A-A

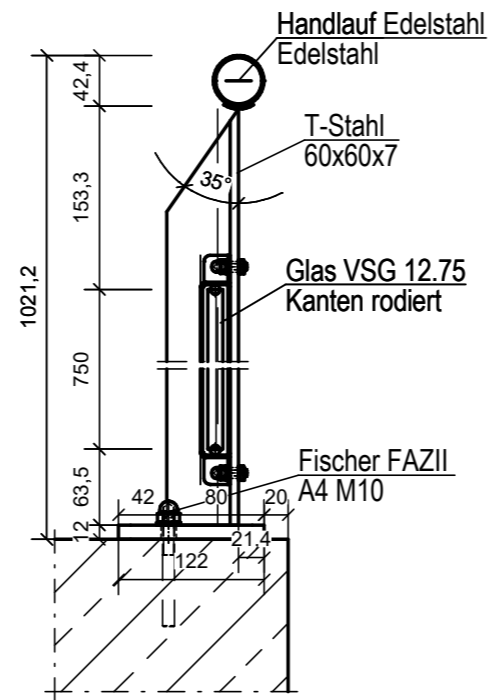
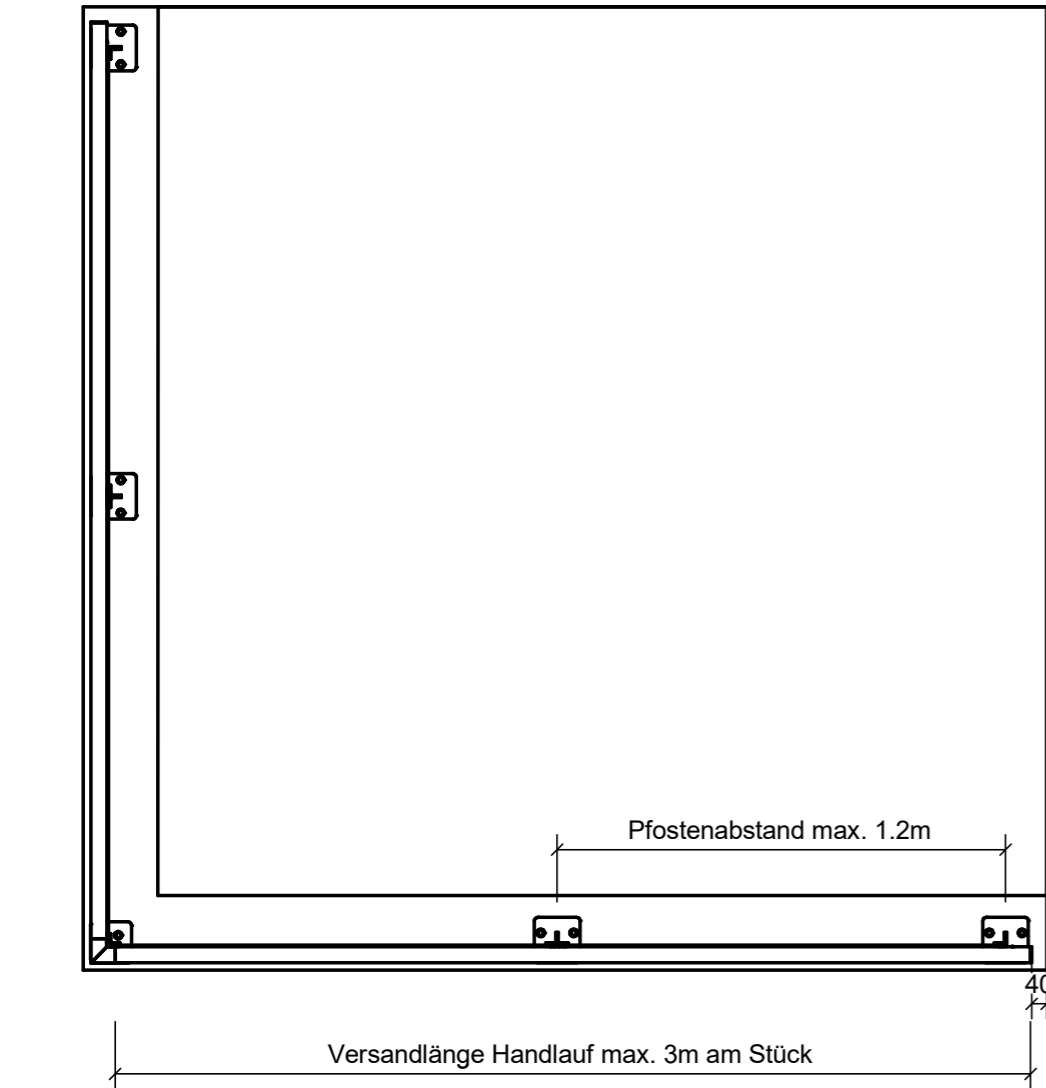
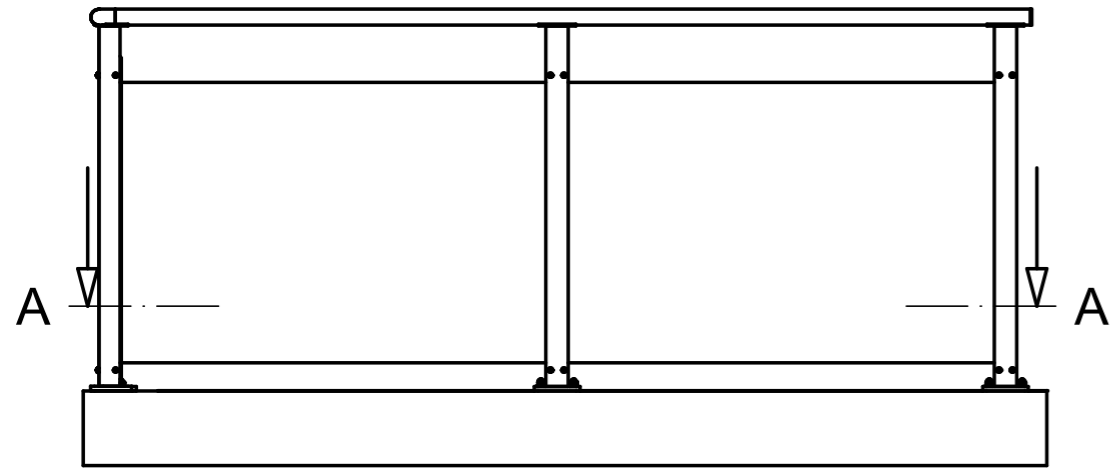